

BEST AVAILABLE COPY

PCT

WORLD INTELLECTUAL PROPERTY ORGANIZATION
International Bureau



INTERNATIONAL APPLICATION PUBLISHED UNDER THE PATENT COOPERATION TREATY (PCT)

(51) International Patent Classification 7 : E21B 43/10		A1	(11) International Publication Number: WO 00/37772
			(43) International Publication Date: 29 June 2000 (29.06.00)
(21) International Application Number: PCT/GB99/04363		(81) Designated States: AU, BR, CA, NO, European patent (AT, BE, CH, CY, DE, DK, ES, FI, FR, GB, GR, IE, IT, LU, MC, NL, PT, SE).	
(22) International Filing Date: 22 December 1999 (22.12.99)		Published With international search report.	
(30) Priority Data:			
9828234.6	22 December 1998 (22.12.98)	GB	
9900835.1	15 January 1999 (15.01.99)	GB	
9923783.6	8 October 1999 (08.10.99)	GB	
9924189.5	13 October 1999 (13.10.99)	GB	
(71) Applicants: PETROLINE WELLSYSTEMS LIMITED [GB/GB]; Offshore Technology Park, Claymore Drive, Bridge of Don, Aberdeen AB23 8GD (GB). ASTEC DEVELOPMENTS LIMITED [GB/GB]; ODS Building, Greenbank Crescent, East Tullos, Aberdeen AB12 3BG (GB).			
(72) Inventors: METCALFE, Paul, David; North Wing, Bucklerburn Steading, Peterculter AB14 0NP (GB). SIMPSON, Neil, Andrew, Abercrombie; Burn of Daff Farm, Downies, Portlethen, Aberdeen AB12 4QX (GB).			
(74) Agents: McCALLUM, William, Potter et al.; Cruikshank & Fairweather, 19 Royal Exchange Square, Glasgow G1 3AE (GB).			

(54) Title: TUBING ANCHOR

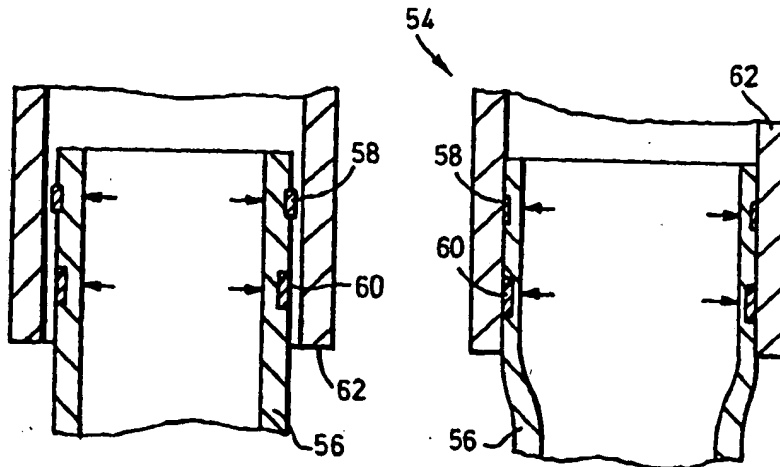

(57) Abstract

A method of installing a liner in a drilled bore below a section of bore previously lined with casing comprises the steps of: running a length of liner into the bore such that at least an upper end of the liner is positioned in overlapping relation with at least a lower end of the casing; and plastically deforming a portion of the liner such that an external face of the portion forms an interference fit with an internal face of a portion of the casing. The interference fit preferably provides both hanging support for the liner and a fluid-tight seal between the liner and casing.

FOR THE PURPOSES OF INFORMATION ONLY

Codes used to identify States party to the PCT on the front pages of pamphlets publishing international applications under the PCT.

AI.	Albania	ES	Spain	LS	Lesotho	SI	Slovenia
AM	Armenia	FI	Finland	LT	Lithuania	SK	Slovakia
AT	Austria	FR	France	LU	Luxembourg	SN	Senegal
AU	Australia	GA	Gabon	LV	Latvia	SZ	Swaziland
AZ	Azerbaijan	GB	United Kingdom	MC	Monaco	TD	Chad
BA	Bosnia and Herzegovina	GE	Georgia	MD	Republic of Moldova	TG	Togo
BB	Barbados	GH	Ghana	MG	Madagascar	TJ	Tajikistan
BE	Belgium	GN	Guinea	MK	The former Yugoslav Republic of Macedonia	TM	Turkmenistan
BF	Burkina Faso	GR	Greece	ML	Mali	TR	Turkey
BG	Bulgaria	HU	Hungary	MN	Mongolia	TT	Trinidad and Tobago
BJ	Benin	IE	Ireland	MR	Mauritania	UA	Ukraine
BR	Brazil	IL	Israel	MW	Malawi	UG	Uganda
BY	Belarus	IS	Iceland	MX	Mexico	US	United States of America
CA	Canada	IT	Italy	NE	Niger	UZ	Uzbekistan
CF	Central African Republic	JP	Japan	NL	Netherlands	VN	Viet Nam
CC	Congo	KE	Kenya	NO	Norway	YU	Yugoslavia
CH	Switzerland	KG	Kyrgyzstan	NZ	New Zealand	ZW	Zimbabwe
CI	Côte d'Ivoire	KP	Democratic People's Republic of Korea	PL	Poland		
CM	Cameroon	KR	Republic of Korea	PT	Portugal		
CN	China	KZ	Kazakistan	RO	Romania		
CU	Cuba	LC	Saint Lucia	RU	Russian Federation		
CZ	Czech Republic	IJ	Lichtenstein	SD	Sudan		
DE	Germany	LK	Sri Lanka	SE	Sweden		
DK	Denmark	LR	Liberia	SG	Singapore		
EE	Estonia						

TUBING ANCHOR

This invention relates to a tubing anchor, such as a liner hanger, that is a arrangement for locating and sealing a section of liner downhole relative to an existing casing. The invention also relates to a method and apparatus for use in providing such an anchor or hanger.

In oil and gas exploration and extraction, it is conventional to line the bores drilled to access subsurface hydrocarbon-bearing formations with steel tubing. The upper section of a bore is typically lined with steel "casing", while the lower section of the bore is provided with "liner", which is hung off the lowermost section of casing. The liner is secured and sealed to the casing using a liner hanger comprising an arrangement of slips and elastomer seals, which seals may also serve to energise the slips.

Conventional liner hangers are relatively complex and expensive and occupy a significant annular space, necessary to accommodate both the gripping slip segments which support the weight of the liner and resist the differential pressure forces which may be generated across the liner/casing overlap and the elastomeric seals which prevent pressure leakage past the overlap. Accordingly, there may be a significant loss in bore diameter at the liner: for example, accommodation of a 7" diameter liner normally requires provision of a 9 5/8" diameter casing,

and a 5" liner a 7" casing.

The maintenance of the integrity of the elastomeric seals used in conventional liner hangers has also proved problematic, particularly in high pressure high temperature wells, which are becoming increasingly more common.

In the majority of cases, the liner section will be cemented in place, by pumping cement slurry down through the liner and back up the annular space between the liner and the borehole wall. Recent developments have resulted in the provision of mechanisms which allow the liner to be rotated during the cementing process, to improve cement coverage around the liner and the subsequent bond between the liner and the bore wall. These mechanisms typically consist of bearings which isolate the slip and seal sections of the liner hanger while the casing is rotated from surface via the liner running tool assembly.

In addition, circulating ports are provided in the liner hanger to allow fluid displaced from the annulus by the cement slurry to bypass the liner hanger mechanism to the point where returning cement can also pass the liner hanger before the liner is finally set, thus ensuring that the annulus is filled with uncontaminated cement slurry.

The provision of these bearings and circulating ports add further complexity to an already complex system.

It is among the objectives of embodiments of the present invention to provide a liner hanger arrangement which obviates and mitigates at least some of these disadvantages. In particular, embodiments of the present

invention provide relatively simple liner hangers which occupy only a very limited volume and which utilise metal-to-metal seals.

5 It is among the objectives of other embodiments of the present invention to provide a downhole method and apparatus for anchoring tubing, particularly expandable tubing, to a section of existing casing.

According to one aspect of the present invention there is provided a method of installing a liner in a drilled 10 bore below a section of bore previously lined with casing, the method comprising the steps of:

15 running a length of liner into the bore such that at least an upper end of the liner is positioned in overlapping relation with at least a lower end of the casing; and

plastically deforming a portion of the liner such that an external face of said portion forms an interference fit with an internal face of a portion of the casing to provide at least one of hanging support for the liner and a fluid-tight seal between the liner and casing. 20

The invention also relates to liner and casing for use in the method. In one embodiment of the invention, at least the portion of liner to be expanded is of a relatively ductile material.

25 The plastic deformation of the portion of liner to create an interference fit with the casing and provide hanging support for the liner obviates the requirement to provide slips or the like on the liner, and also a

mechanism to energise the slips, and thus the liner outside diameter may be relatively close to the inside diameter of the casing. The creation of fluid-tight seal obviates the requirement to provide conventional elastomeric seals requiring setting and energising.

Preferably, said portion of liner is deformed by rolling expansion, that is an expander member is rotated within the liner with a face in rolling contact with an internal face of said portion. The expander member may describe the desired diameter and is preferably urged radially outwardly into contact with the liner. Such rolling expansion causes compressive plastic deformation or yield of the liner and a localised reduction in wall thickness resulting in a subsequent increase in liner diameter.

Preferably, said deformed portion of the liner is annular.

Preferably, the portion of liner is deformed to create a pressure-tight seal between the liner and casing. Most preferably, the seal formed is a metal-to-metal seal. Conveniently, the portion of liner includes a relatively soft material, such as a relatively soft metal, which is plastically deformed during the expansion of the liner portion. The soft metal may be provided as an annular coating or insert. In other embodiments other sealing materials may be utilised, such as elastomers, or the relatively soft material may be provided on the casing.

The portion of liner may be deformed to extend into or

otherwise engage a preformed profile in the casing. A step of a method in accordance with an embodiment of the invention may involve deforming the casing to define the profile prior to running the liner into the bore. Alternatively, the portion of casing may also be deformed together with the liner, and the deformation of the casing may be elastic or plastic. The liner may be deformed at two or more axially spaced locations. Thus, the liner, and possibly also the casing, may be deformed to define a plurality of axially spaced profiles.

The liner may be initially secured in the casing, at least against relative rotation, by deforming the liner, in particular by radially extending circumferentially spaced areas of the liner to form corresponding areas of interference fit between the liner and the casing. Preferably, these areas are then extended circumferentially to form annular areas of interference fit between the liner and casing.

The portion of the liner may carry relatively hard material on its external face, which material will tend to bite into the opposing faces of the liner and casing to provide a more secure coupling therebetween. The material is preferably in the form of relatively small discrete particles or pieces, such as balls, chips or the like of relatively hard metal such as tungsten carbide. The hard material may be held in a matrix of softer material.

The method may further comprise the step of cementing the liner in the bore. This may be achieved by pumping

cement from surface to the lower end of the liner, preferably through a combined running and cementing string and tool, directing the cement into the annulus between the liner and the bore wall and displacing well fluid from the annulus, to substantially fill the annulus with cement. Preferably, the portion of the liner is expanded once the cement is in place in the annulus; the displaced well fluid may therefore pass between the upper end of the liner and the lower end of the casing. Preferably, the liner is rotated as the cement is passed into the annulus; thus, there is preferably a releasable coupling between the running tool and the liner to permit transfer of torque therebetween.

Preferably, the liner is run into the bore on a running tool carrying an expander including a body and at least one radially extendable member mounted thereon, the running tool being rotatable to move the member around the portion of the liner to create the desired deformed portion. Preferably, the member is a roller, and the roller may define a raised surface portion to create a high pressure contact area. The expander may be provided with two or more rollers, and a plurality of the rollers may be radially movable. Most preferably, the member is fluid pressure actuated, but in other embodiments may be mechanically actuated. Conveniently, the member is coupled to an axially movable fluid pressure actuated piston, the piston defining a cam face for engaging a cooperating cam face on the member. In other embodiments, the expander may

include a cone or the like, and the cone may carry a number of rollers for engaging and expanding the liner. A cleaning pig, a wiper, or the like may be run through the liner running string and expander prior to activating the expander.

5 According to a further aspect of the present invention there is provided a method of securing a liner in a drilled bore to a section of previously fitted casing, the method comprising the step of circumferentially expanding a portion of the liner by compressive plastic deformation to produce a localised reduction in wall thickness such that an external face of said portion forms an interference fit with an internal face of a portion of the casing to provide at least one of hanging support for the liner and a fluid-tight seal between the liner and casing.

10 Preferably, said portion of liner is deformed by rolling expansion, that is an expander member is rotated within the liner with a face in rolling contact with an internal face of said portion. The expander member may describe the desired diameter and is preferably urged radially outwardly into contact with the liner.

15 According to another aspect of the present invention, there is provided a liner running and setting tool comprising: a body for mounting on a running string and for location within a portion of liner to be positioned within a portion of casing; and a radially movable expander member mounted on the body, the member being movable to plastically deform the liner portion such that an external.

face of the portion forms an interference fit with an internal face of the casing portion to provide at least one of hanging support for the liner and a fluid-tight seal between the liner and casing.

5 Preferably, the tool is adapted to be selectively rotatable relative to the liner and the expander member is a roller such that the portion of liner may be deformed by rolling expansion, that is the expander member is rotated within the liner with a face in rolling contact with an
10 internal face of said portion. Preferably, the roller defines a raised surface portion to create a high pressure contact area. The tool may be provided with two or more rollers, and a plurality of the rollers may be radially movable.

15 Preferably, the member is fluid pressure actuated. Conveniently, the member is coupled to an axially movable piston, the piston defining a cam face for engaging a cooperating cam face on the member. In other embodiments, the expander may include a cone or the like, and the cone
20 may carry a number of rollers for engaging and expanding the liner. Alternatively, the members may be piston mounted. The tool may include axially spaced expansion members, whereby the liner may be deformed simultaneously at two spaced locations. However, it is preferred that the
25 expansion of the liner occurs only at one axial location at a time; the expansion member may then be moved axially within the liner to another location if desired.

Preferably, the tool defines a throughbore to permit

cement to be passed through the tool.

Preferably also, the tool comprises a coupling for releasably engaging the liner to permit transfer of torque therebetween. The coupling may be released on activation
5 of the expander member, to permit rotation of at least the expander member relative to the liner.

The tool may be provided in combination with a section of liner, wherein at least the portion of liner to be expanded is of a relatively ductile material. Preferably,
10 the portion of liner includes a relatively soft material on an outer surface thereof, such as a relatively soft metal, which may be plastically deformed during the expansion of the liner portion. The soft metal may be provided as an annular coating or insert. In other embodiments other
15 sealing materials may be utilised, such as elastomers. The portion of the liner may carry relatively hard material on its external face, which material will tend to bite into the opposing faces of the liner and casing to provide a more secure coupling therebetween. The material is
20 preferably in the form of relatively small discrete pieces, such as balls, chips or the like of relatively hard metal such as tungsten carbide. The hard material may be held in a matrix of softer material.

According to a still further aspect of the present
25 invention there is provided a solid liner wherein at least a portion of the liner is of a relatively ductile material, to facilitate deformation and circumferential expansion thereof.

Said portion of the liner may be formed by selectively heat treating a section of the liner, or may be formed of a different material and be coupled, for example by welding or via a screw thread, to the less ductile portion of
5 liner.

According to a still further aspect of the present invention there is provided a method of anchoring expandable tubing downhole, the method comprising: running a section of expandable tubing into a bore such that at
10 least a portion of the expandable tubing is located within of a section of existing tubing; locating a radially extendable tool within said portion; and activating said tool to plastically deform and circumferentially expand said portion into contact with the existing tubing and
15 anchor the expandable tubing thereto.

The invention thus allows a section of expandable tubing to be anchored in a bore without requiring the provision of conventional anchors, tubing hangers or coupling arrangements, such as radially extendable keys and
20 corresponding profiles.

Said portion of the expandable tubing will typically be an end portion of the tubing, and may be the leading or following end of the tubing.

Preferably, relatively ductile material, typically a
25 ductile metal, is provided between the portion of expandable tubing and the existing tubing, and conveniently the material is carried on the outer surface of the expandable tubing. Thus, on expansion of the inner tubing

the ductile material will tend to flow or deform away from the points of contact between the less ductile material of the expandable tubing and existing tubing, creating a relatively large contact area; this will improve the quality of the seal between the sections of tubing. Most preferably, the material is provided in the form of a plurality of axially spaced bands. The expandable tubing and the existing tubing will typically be formed of steel, while the relatively ductile material may be lead or another relatively soft metal, or may even be an elastomer.

Preferably, relatively hard material may be provided between the portion of expandable tubing and the existing tubing, such that on circumferential expansion of the expandable tubing the softer material of one or both of the expandable and existing tubing deforms to accommodate the harder material and thus facilitates in anchoring the expandable tubing. Most preferably, the relatively hard material is provided in the form of relatively small individual elements, such as sharps, grit or balls of carbide or some other relatively hard material, although the material may be provided in the form of bands or the like. Most preferably, the relatively hard material is carried in a matrix of relatively ductile material.

Preferably, the radially extendable tool is run into the bore together with the expandable tubing. Preferably, the tool defines a plurality of circumferentially spaced tubing engaging portions, at least one of which is radially extendable. Preferably, the tool is rotated following

extension of said at least one tubing engaging portions to produce an circumferential contact area between the expandable tubing and the existing tubing.

5 Preferably, following anchoring of the expandable tubing in the existing tubing, the tool is advanced through the tubing to expand the tubing.

10 According to another aspect of the present invention there is provided apparatus for use in anchoring expandable tubing downhole, the apparatus comprising a body for location in a portion of expandable tubing and carrying a plurality of circumferentially spaced tubing engaging portions, at least one of the tubing engaging portions being radially extendable to increase the effective diameter defined by the tubing engaging portions and to produce plastic deformation of the expandable tubing where the tubing engaging portions contact the expandable tubing sufficient to anchor the expandable tubing in a surrounding tubing.

15 The invention also relates to the use of such an apparatus to form an anchor.

20 Preferably, the apparatus comprises at least two and preferably three tubing engaging portions.

25 Preferably, the tubing engaging portions define rolling surfaces, such that following radial extension of said at least one tubing engaging portion the body may be rotated to create a circumferentially extending area of contact between the expandable tubing and the surrounding tubing. In other embodiments the extension may be created

in a step-wise fashion.

Most preferably, the tubing engaging portions are in the form of radially movable rollers. The rollers may have tapered ends for cooperating with tapered supports. At least one of the tapered supports may be axially movable, such movement inducing radial movement of the rollers. Preferably also, each roller defines a circumferential rib, to provide a small area contact surface.

Preferably, said at least one tubing engaging portion is fluid actuated. Most preferably, the tubing engaging portion is coupled to a piston; by providing a relatively large piston area with respect to the area of the portion which comes into contact with the tubing it is possible to produce high pressure forces on the tubing, allowing deformation of relatively thick and less ductile materials, such as the thicknesses and grades of steel conventionally used in downhole tubing and casing. Most preferably, a support for the tubing engaging portion is coupled to a piston, preferably via a bearing or other means which permits relative rotational movement therebetween.

The apparatus may be provided in conjunction with a downhole motor, or the apparatus may be rotated from surface.

These and other aspects of the present invention will now be described, by way of example, with reference to the accompanying drawings, in which:

Figures 1 and 2 are schematic illustrations of the formation of a liner hanger in accordance with a first

embodiment of the present invention;

Figures 3 and 4, Figures 5 and 6, Figures 7 and 8,
Figures 9 and 10 and Figures 11 and 12 are schematic
illustrations of the formation of liner hangers in
accordance with other embodiments of the present invention;

Figures 13 to 17 are schematic views illustrating
steps in the running and setting of a liner in accordance
with a preferred embodiment of the present invention; and

Figures 18 and 19 are schematic sectional plan views,
on lines 18-18 and 19-19 of Figures 15 and 16 respectively,
illustrating the initial temporary setting of the liner.

A variety of liner hangers in accordance with
embodiments of the present invention will first be
described, followed by a description of an apparatus and
method which may be utilised to form the hangers.

Reference is first made to Figures 1 and 2 of the
drawings which are schematic illustrations of the formation
of a liner hanger 10 in accordance with a first embodiment
of the present invention. The figures show the lower end
of a section of pre-installed casing 12 and the upper end
of a section of liner 14 which has been run into a borehole
lined with casing 12. The upper end of the liner 14 is
positioned in overlapping relation with the lower end of
the casing 12.

The casing 12 features two axially spaced annular
female profiles 16, 17. As will be described, the upper
end of the liner 14 is deformed by rolling expansion, that
is an expander member in the form of a roller is rotated

within the liner 14 with a face in rolling contact with the internal face of the liner, to cause compressive plastic deformation of the liner 14 and a localised reduction in wall thickness resulting in a subsequent increase in liner diameter, as is apparent from Figure 2. The expansion is carried out in two steps, and the expanding rollers feature a raised portion or rib such that the liner 14 experiences greater deformation at the area in contact with the raised portion, the raised portion being located adjacent the casing profile 16, to form a corresponding male profile 18 in the liner 14. A second male profile 19 is created by moving the roller expander to a second lower location for the second step of the expansion process.

The interference fit between the expanded liner 14 and the casing 12, and also the cooperation between the profiles 16, 17, 18 and 19 is such that the resulting liner hanger 10 provides both hanging support for the liner 14 and a pressure-tight seal between the liner 14 and the casing 12.

To enhance the grip between the liner 14 and the casing 12, the liner 14 carries chips of carbide 20 held in a matrix of softer metal; on deformation of the liner 14, the carbide chips bite into the opposing faces of the liner 14 and casing 12.

Reference is now made to Figures 3 and 4 of the drawings, which illustrate a liner hanger 24 in accordance with a second embodiment of the present invention. The method of forming the liner hanger 24 is substantially the

same as described above, however the liner 26 is provided with bands of relatively soft material 28, 29 at the locations corresponding to the casing profiles 30, 31. Accordingly, when the liner 26 is deformed to create the male profiles 32, 33, the bands of ductile metal 28, 29 extend into the casing profiles 29, 30 and deform to provide a sealing contact with the opposing surfaces of the profiles 29, 30.

Reference is now made to Figures 5 and 6 of the drawings, which illustrate a liner hanger 36 in accordance with a third embodiment of the present invention. Like the second embodiment, the liner 38 carries bands of relatively ductile material 39, 40, however there are no preformed profiles provided in the casing 42. In this embodiment, sufficient internal force is applied to the liner 38 to cause compressive plastic deformation of the liner 38 and subsequent radial expansion of the casing 42 up to and exceeding the casing yield point.

Reference is now made to Figures 7 and 8 of the drawings, which illustrate a liner hanger 36 in accordance with a fourth embodiment of the present invention. In this embodiment, sufficient internal rolling compression and subsequent expansion of the upper section of the liner 48 creates high radial interference between the outside diameter of the upper section of the liner 48 and the inside diameter of the lower section of the casing 50.

Reference is now made to Figures 9 and 10 of the drawings, which illustrates a liner hanger 54 in accordance

with a fifth embodiment of the present invention. The method of formation of the liner hanger is similar to that of the liner hanger 46 as described above, however in this embodiment the outer face of the upper section of the liner 56 carries a band of ductile metal 58 and an annular elastomeric seal 60, such that on expansion of the liner 56 the metal 58 is deformed and flows between the liner 56 and the casing 62, and the seal 60 is brought into sealing contact with the casing 62.

Reference is now made to Figures 11 and 12 of the drawings which illustrates a liner hanger 66 in accordance with a sixth embodiment of the present invention. In this embodiment, the casing 68 is formed of expandable tubing which has only been partially expanded at its lower end 70 to form a cone 72. The liner 74 is then run into the casing 68 and the liner top 76 expanded to form a matching cone 78 to the casing cone 72, such that the liner 74 may be hung from the casing 68. The upper end of the liner 74 is then subsequently expanded by compressive deformation to create a pressure seal, as illustrated in Figure 12.

Reference is now made Figures 13 through 17, which illustrate the stages in the running and cementing of a liner in accordance with a preferred embodiment of the present invention, and also illustrate the apparatus which may be utilised to form a liner hanger.

Reference is first made to Figure 13 of the drawings, which illustrates the liner 100 which has been run into the uncased section of a bore 102, below the lowermost casing.

section 104. An upper section of the liner 100a overlaps the lower end of the casing 104, this section of liner 100a being formed of a relatively ductile material and being welded to the upper end of the lower section of liner 100b.

5 The liner 100 is run in to the bore on a running and cementing string 106, the liner 100 being mounted to the string 106 via a rotary hydraulic expander 108 and a locking swivel 110. The expander 108 is located at the upper end of the liner, with the swivel 110 below, and a

10 wiper plug 112 is mounted to the lower end of the swivel 110. The liner 100 itself defines a stop collar 114 and the lower end of the liner 100 is provided with a float shoe 116 including two one-way valves 118.

The liner 100 is coupled to the swivel 110 by a series

15 of retractable pins which, in the initial configuration, prevent relative axial movement between the string 106 and the liner 100. A further series of pins extends from the expander 108 and, in the initial configuration, prevent relative rotational movement between the string 106 and the

20 liner 100.

From Figure 13 it will be noted that the expander 108 and swivel 110 are tubular, such that cement and other fluids may be pumped from the surface through the string 106, and the expander 108 and the swivel 110 through the

25 interior of the liner 100 and out from the valves 118 in the float shoe 116. As cement slurry is pumped in, as illustrated in Figure 14 of the drawings, the fluid in the bore externally of the liner 100, and in particular the

fluid in the annulus 120 between the liner 100 and the uncased bore wall 122 is displaced upwardly through the annular gap 124 between the lower end of the casing and the upper end of the liner. This fluid may be "clean" fluid pumped through the string 106 ahead of the cement, in order to displace the well fluid which originally occupied the annulus 120.

As the cement is being pumped into the annulus 120 the string 106 is rotated from surface, to ensure an even distribution of cement throughout the annulus 120. Suitable seals located above and below the expander 108 prevent contamination of the expander by cement during the cementing operation.

The predetermined volume of cement slurry that is pumped into the bore is followed by a dart 126, which is itself followed by clean mud or water; the dart 126 is pumped down through the string 106, the expander 108 and the swivel 110. The dart 126 lands in the wiper plug 112, and pulls the plug 112 from the swivel 110.

The dart 126 then continues to move downwardly through the string 106, with the wiper plug 112, to "clean" the interior of the liner, until the plug 112 engages the stop collar 114, as shown in Figure 16.

At this point, the fluid pressure within the string 106 will increase, indicating that the cementing phase of the liner hanging operation is complete, and allowing activation of the rotary hydraulic expander 108. Reference should now also be made to Figures 18 and 19 of the

drawings, which illustrate the schematic sections on lines 18 - 18 and 19 - 19 of Figures 15 and 16, respectively. The expander 108 comprises three rollers 128 mounted in a body 130 and radially movable relative to thereto. In the preferred embodiment, the rollers 128 have tapered ends for co-operating with a corresponding taper on an annular piston which, when exposed to elevated string bore pressure, moves axially within the expander body 130 and urges the rollers 128 radially outwards. Figure 18 illustrates the initial position of the rollers 128 relative to the liner 100 and casing 104 (it should be noted that the diameters of the rollers 128 have been exaggerated), and on application of elevated fluid pressure to the interior of the expander 108 the rollers 128 are pushed outwardly, as illustrated in Figure 19 of the drawings. The outward movement of the rollers 128 is such that the wall of the liner 100 is deformed to create three initial areas of contact 132 between the liner outside diameter and casing inside diameter, which prevent further relative rotation between the liner 100 and the casing 104. The deformation of the liner 100 also disengages the liner from the coupling pins on the expander 108, allowing relative rotation between the expander 108 and the liner 100.

25 The string 106 and expander 108 are then rotated from surface, and thus the expander 108 rotates relative to the liner 100, the rollers 128 progressing around the inner diameter of the liner 100, in rolling contact therewith.

The contact between the rollers 128 and the liner 100 causes compressive plastic deformation of the liner 100 and a localised reduction in wall thickness resulting in a subsequent increase in liner diameter, such that the liner outside diameter forms an interference fit with the casing inside diameter. Thus, a liner hanger, such as those as
5 illustrated in Figures 1 to 12, may be created.

The running string 106, with the expander 108 and the swivel 110, is then pulled out of the hole, as shown in
10 Figure 17, the locking pins extending between the swivel 110 and the liner 100 being arranged to disengage from the liner 100 when the swivel 110 is moved downwards as elevated fluid pressure is applied to the string 106.

It will be apparent to those of skill in the art that
15 the liner hanger thus formed is relatively simple and slim in profile, thus providing enhanced reliability and minimising the loss of diameter between the casing and liner.

It will also be apparent to those of skill in the art
20 that the above described embodiments are merely exemplary, and that various modifications and improvements may be made thereto without departing from the scope of the present invention. For example, although reference is made
25 primarily herein to liner hangers, the invention may be utilised in locating and sealing many different forms of expandable tubing in existing tubing.

CLAIMS

1. A method of installing a liner in a drilled bore below a section of bore previously lined with casing, the method comprising the steps of:

5 running a length of liner into the bore such that at least an upper end of the liner is positioned in overlapping relation with at least a lower end of the casing; and

10 plastically deforming a portion of the liner such that an external face of said portion forms an interference fit with an internal face of a portion of the casing to provide at least one of hanging support for the liner and a fluid-tight seal between the liner and casing.

15 2. The method of claim 1, wherein said portion of liner is deformed by rolling expansion, that is an expander member is rotated within the liner with a face in rolling contact with an internal face of said portion, to cause compressive plastic deformation of the liner and a localised reduction in wall thickness resulting in a
20 subsequent increase in liner diameter.

3. The method of claim 1 or 2, wherein said deformed portion of the liner is annular.

4. The method of claim 1, 2 or 3, wherein the portion of

liner is deformed to create a pressure-tight seal between the liner and casing.

5. The method of claim 4, wherein the seal formed is a metal-to-metal seal.

5 6. The method of claim 4 or 5, further comprising providing the portion of liner with a band of relatively soft metal which is plastically deformed during the expansion of the liner portion.

10 7. The method of any of the preceding claims, wherein the portion of liner is deformed to extend into a preformed profile in the casing.

8. The method of claim 7, further comprising deforming the casing to define the profile prior to running the liner into the bore.

15 9. The method of claim 7, further comprising deforming the portion of casing together with the liner.

10. The method of any of the preceding claims, wherein the liner is deformed at two or more axially spaced locations.

20 11. The method of any of the preceding claims, wherein the liner is initially secured relative to the casing by deforming the liner by radially extending circumferentially

spaced areas of the liner to form corresponding areas of interference fit between the liner and the casing.

12. The method of claim 11, wherein said areas are then extended circumferentially to form annular areas of interference fit between the liner and casing.

13. The method of any of the preceding claims, further comprising the step of cementing the liner in the bore.

14. The method of claim 13, wherein cementing is achieved by pumping cement from surface to the lower end of the liner through a combined running and cementing string and tool, directing the cement into the annulus between the liner and the bore wall and displacing fluid from the annulus, to substantially fill the annulus with cement.

15. The method of claim 13 or 14, wherein the portion of the liner is expanded once the cement is in place in the annulus.

16. The method of claim 15, wherein the liner is rotated as the cement is passed into the annulus.

17. The method of any of the preceding claims, wherein the liner is run into the bore on a running tool carrying an expander including a body and at least one radially

extendable member mounted thereon, the running tool being rotatable to move the member around the portion of the liner to create the desired deformed portion.

5 18. A method of securing a liner in a drilled bore to a section of previously fitted casing, the method comprising the step of deforming a portion of the liner by compressive plastic deformation to produce a localised reduction in wall thickness and subsequent increase in diameter such that an external face of said portion forms an interference fit with an internal face of a portion of the casing to provide at least one of hanging support for the liner and a fluid-tight seal between the liner and casing.

10

19. The method of claim 18, wherein said portion of liner is deformed by rolling expansion.

15 20. A liner running and setting tool comprising: a body for mounting on a running string and for location within a section of liner to be positioned within a section of casing; and a radially extendable expander member mounted on the body, the member being movable to plastically deform a portion of the liner section such that an external face of the portion forms an interference fit with an internal face of a portion of the casing section to provide at least one of hanging support for the liner and a fluid-tight seal between the liner and casing.

20

21. The tool of claim 20, wherein the tool is adapted to be selectively rotatable relative to the liner and the expander member is a roller such that the portion of liner may be deformed by rolling expansion, that is the expander member is rotated within the liner with a face in rolling contact with an internal face of said portion.
22. The tool of claim 21, wherein the roller defines a raised surface portion to create a high pressure contact area.
23. The tool of claim 22, wherein the tool is provided with two or more rollers.
24. The tool of claim 23, wherein a plurality of the rollers are radially movable.
25. The tool of any of claims 20 to 24, wherein the member is fluid pressure actuated.
26. The tool of claim 25, wherein the member is coupled to an axially movable piston, the piston defining a cam face for engaging a cooperating cam face on the member.
27. The tool of any of claims 20 to 26, wherein the tool defines a through bore to permit fluid to be passed through the tool.

28. The tool of any of claim 20 to 27, wherein the tool comprises a coupling for releasably engaging the liner to permit transfer of torque therebetween.
29. The tool of any of claims 20 to 28, in combination with a section of liner, wherein at least the portion of
5 liner to be expanded is of a relatively ductile material.
30. The tool and liner combination of claim 29, wherein the portion of liner includes an annular band of relatively soft material on an outer surface thereof.
- 10 31. The tool and liner combination of claim 29 or 30, wherein the portion of the liner carries relatively hard material on an external face, which material will tend to bite into the opposing faces of the liner and casing to provide a more secure coupling therebetween.
- 15 32. The tool and liner combination of claim 31, wherein the hard material is in the form of relatively small discrete pieces.
33. The tool and liner combination of claim 32, wherein the hard material is held in a matrix of softer material.
- 20 34. A solid liner wherein at least a portion of the liner is of a relatively ductile material, to facilitate radial expansion thereof.
-

35. A method of anchoring expandable tubing downhole, the method comprising: running a section of expandable tubing into a bore such that at least a portion of the expandable tubing is located within of a section of existing tubing; locating a radially extendable tool within said portion; and activating said tool to plastically deform said portion into contact with the existing tubing and anchor the expandable tubing thereto.
36. A method of anchoring expandable tubing in a drilled bore to a section of existing casing, the method comprising the step of deforming a portion of the tubing by compressive plastic deformation to produce a localised reduction in wall thickness and subsequent increase in diameter such that an external face of said portion forms an interference fit with an internal face of a portion of the casing.
37. The method of claim 36, wherein said portion of tubing is deformed by rolling expansion.

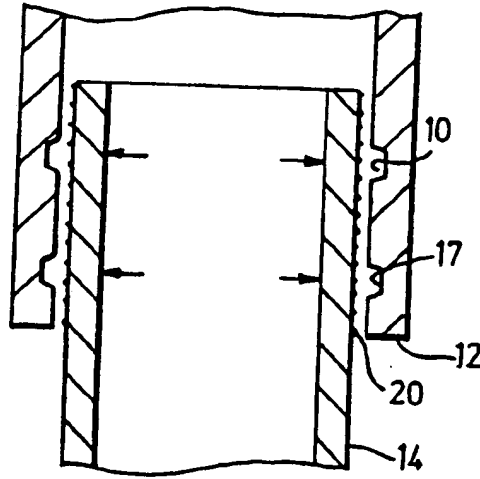

Fig. 1

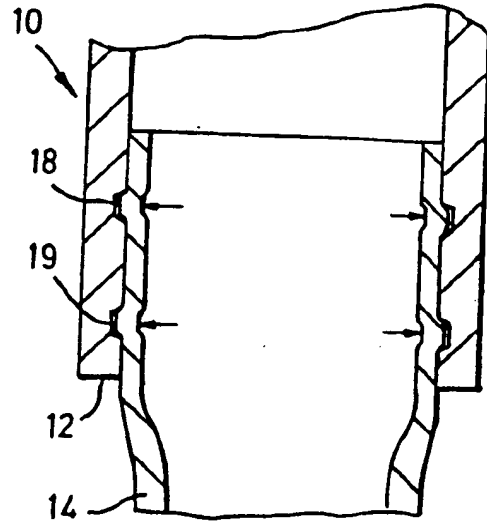

Fig. 2

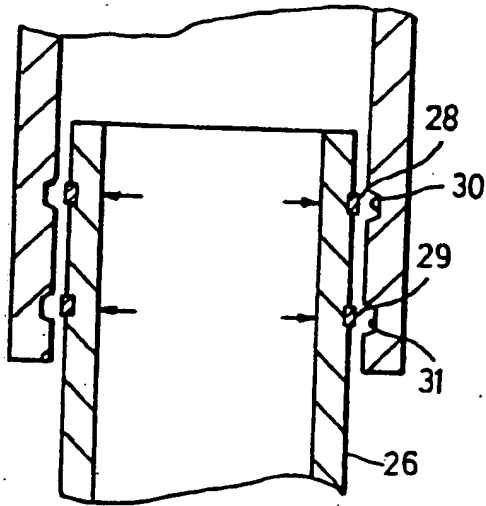

Fig. 3

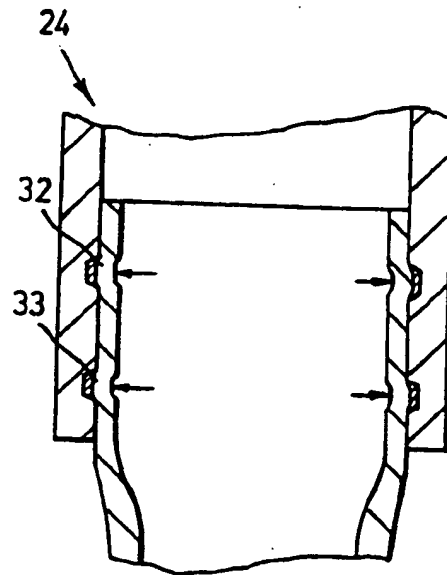

Fig. 4

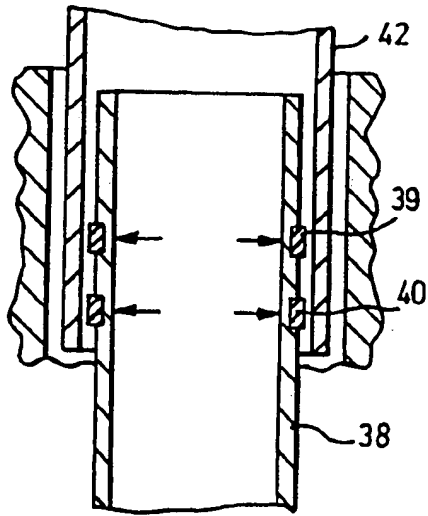

Fig.5

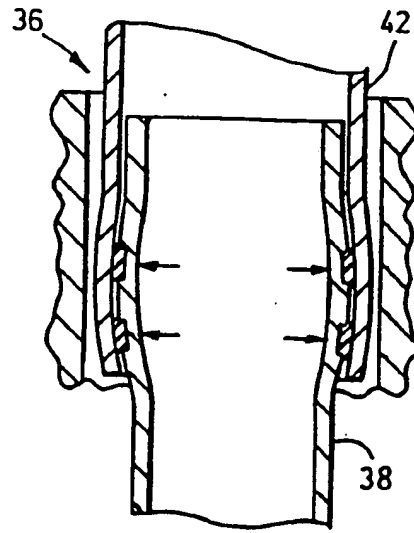

Fig.6

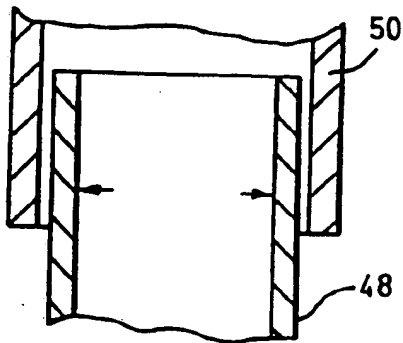

Fig.7

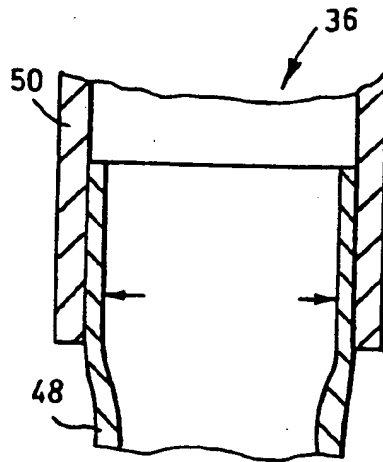

Fig.8

3/6

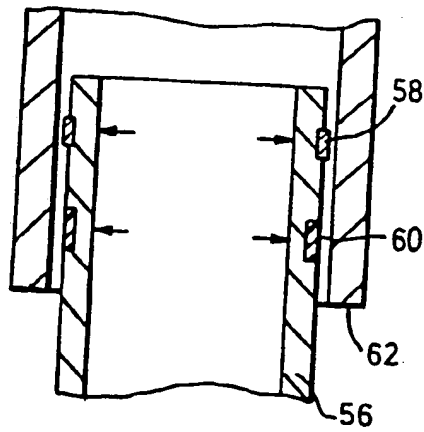

Fig. 9

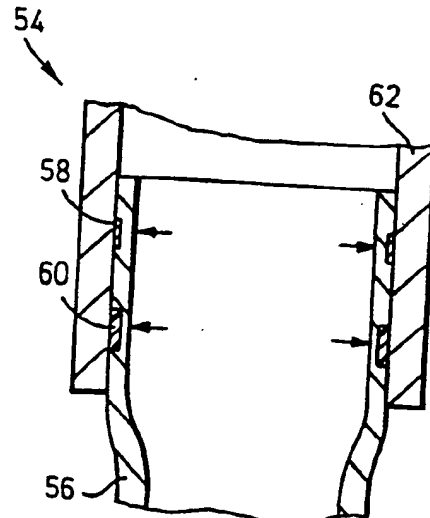

Fig. 10

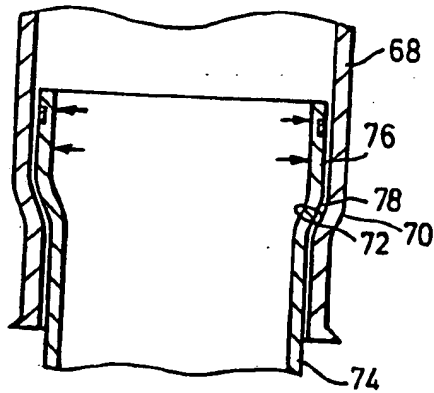

Fig. 11

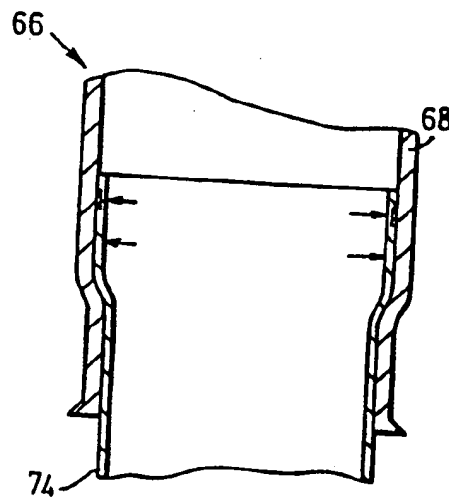

Fig. 12

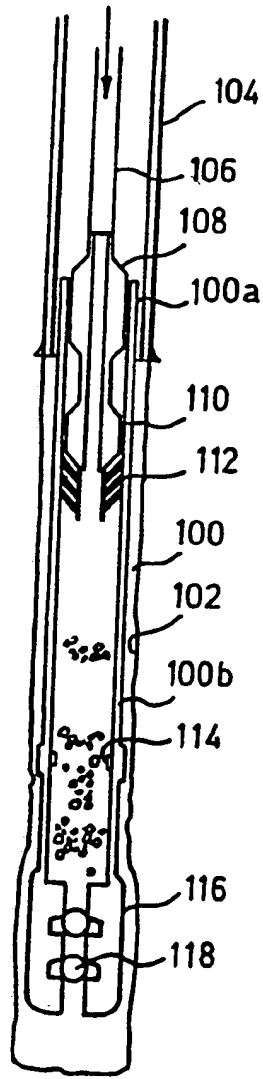

Fig. 13

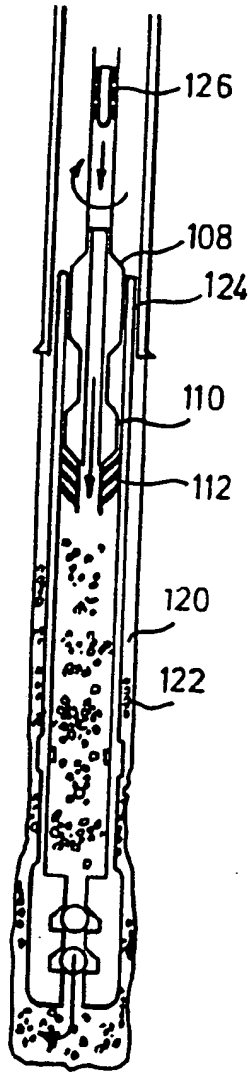

Fig. 14

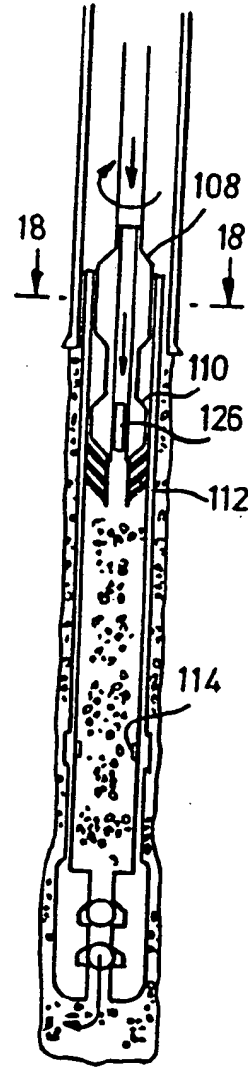

Fig. 15

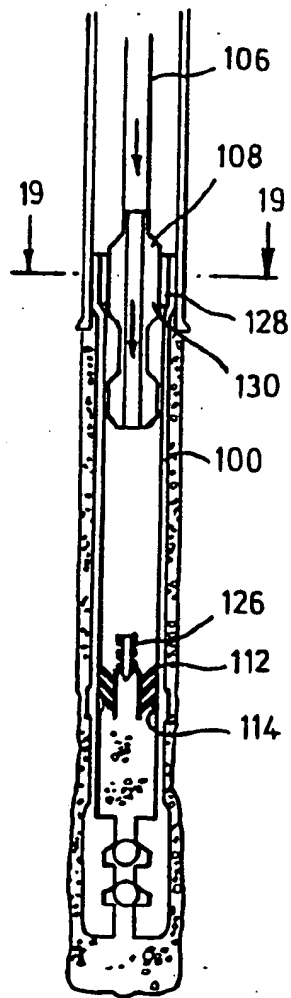

Fig. 16

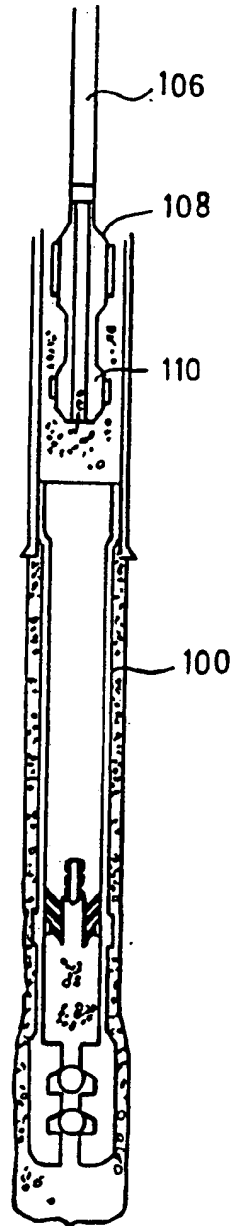

Fig. 17

6/6

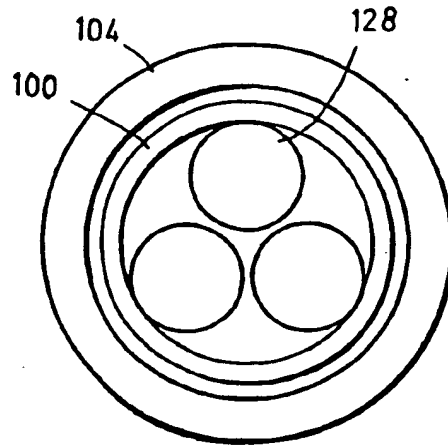

Fig. 18

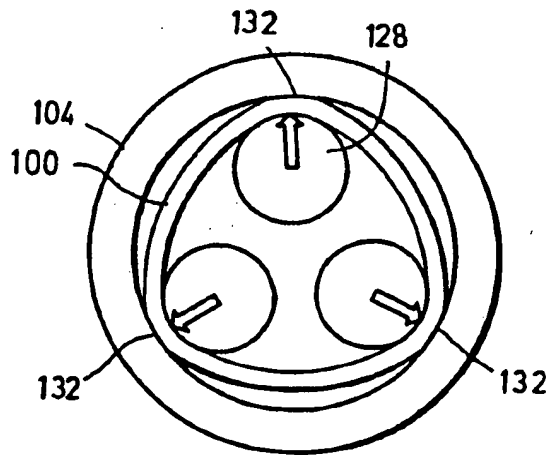

Fig. 19

INTERNATIONAL SEARCH REPORT

International Application No
PCT/GB 99/04363

A. CLASSIFICATION OF SUBJECT MATTER
IPC 7 E21B43/10

According to International Patent Classification (IPC) or to both national classification and IPC

B. FIELDS SEARCHED

Minimum documentation searched (classification system followed by classification symbols)
IPC 7 E21B

Documentation searched other than minimum documentation to the extent that such documents are included in the fields searched

Electronic data base consulted during the international search (name of data base and, where practical, search terms used)

C. DOCUMENTS CONSIDERED TO BE RELEVANT

Category *	Citation of document, with indication, where appropriate, of the relevant passages.	Relevant to claim No.
X	EP 0 881 354 A (SOFITECH NV ;SCHLUMBERGER CIE DOWELL (FR)) 2 December 1998 (1998-12-02) claim 1 page 4, column 5, line 33-35 figures 5-7	1, 3, 4, 10, 13-15, 18, 34, 36
Y	---	2, 19, 35
Y	US 2 627 891 A (P.B. CLARK) 10 February 1953 (1953-02-10) figures 1, 2 column 3, line 39-57 ---	2, 19, 35
	-/--	

Further documents are listed in the continuation of box C.

Patent family members are listed in annex.

* Special categories of cited documents:

- "A" document defining the general state of the art which is not considered to be of particular relevance
- "E" earlier document but published on or after the international filing date
- "L" document which may throw doubts on priority claim(s) or which is cited to establish the publication date of another citation or other special reason (as specified)
- "O" document referring to an oral disclosure, use, exhibition or other means
- "P" document published prior to the international filing date but later than the priority date claimed

- "T" later document published after the international filing date or priority date and not in conflict with the application but cited to understand the principle or theory underlying the invention
- "X" document of particular relevance; the claimed invention cannot be considered novel or cannot be considered to involve an inventive step when the document is taken alone
- "Y" document of particular relevance; the claimed invention cannot be considered to involve an inventive step when the document is combined with one or more other such documents, such combination being obvious to a person skilled in the art.
- "3" document member of the same patent family

Date of the actual completion of the international search

22 February 2000

Date of mailing of the international search report

03/03/2000

Name and mailing address of the ISA
European Patent Office, P.B. 5818 Patentlaan 2
NL - 2280 HV Rijswijk
Tel. (+31-70) 340-2040, Tx. 31 651 epo nl,
Fax: (+31-70) 340-3016

Authorized officer:

Schouten, A

INTERNATIONAL SEARCH REPORT

International Application No
PCT/GB 99/04363

C.(Continuation) DOCUMENTS CONSIDERED TO BE RELEVANT

Category *	Citation of document, with indication, where appropriate, of the relevant passages	Relevant to claim No.
X,P	WO 99 06670 A (SHELL CANADA LTD ;SHELL INT RESEARCH (NL)) 11 February 1999 (1999-02-11) page 4, line 16-35 page 5, line 32 -page 6, line 15 figure 2 -----	1, 3, 4, 10, 13-15, 18, 34, 36

INTERNATIONAL SEARCH REPORT

Information on patent family members

International Application No
PCT/GB 99/04363

Patent document cited in search report	Publication date	Patent family member(s)	Publication date
EP 0881354 A	02-12-1998	CA 2234386 A NO 982371 A	27-11-1998 30-11-1998
US 2627891 A	10-02-1953	NONE	
WO 9906670 A	11-02-1999	AU 9161598 A	22-02-1999